



T110BT



T110BT

Quick Start Guide
Guide de démarrage rapide

1 What's in the box

T110BT

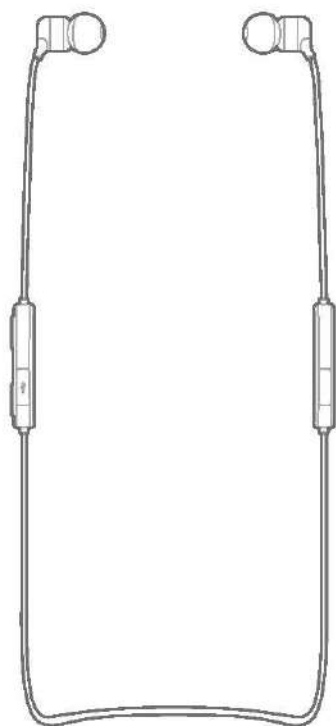

x 1

Charging cable



x 1

Ear tips

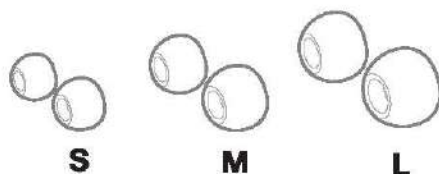

x 3 pairs

Warranty card, Warning card, Safety sheet and QSG

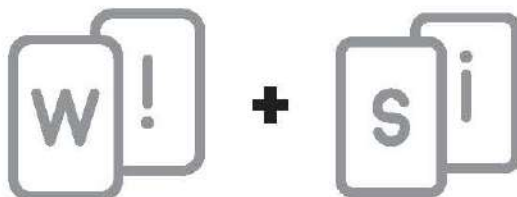

x 1

T110BT

Quick Start Guide
Guide de démarrage rapide

2 Overview

1. Buttons and LEDs

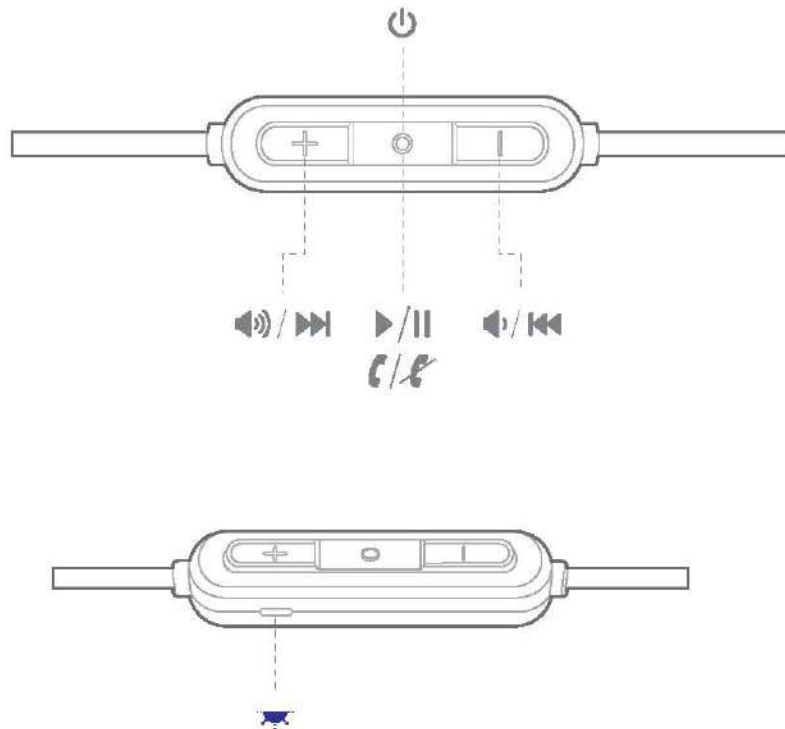

2. Connection

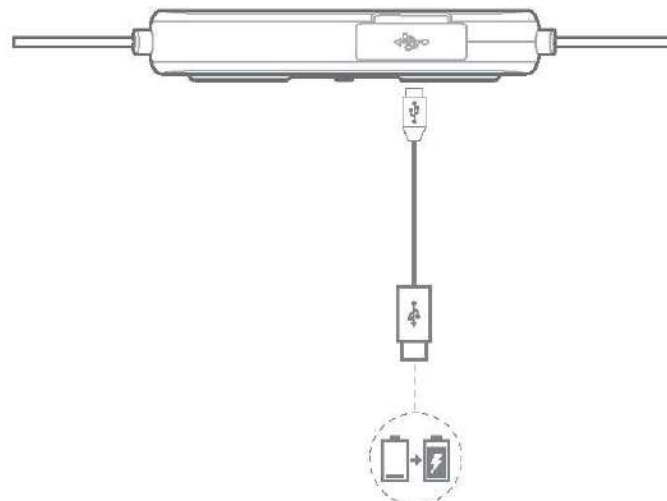

T110BT

Quick Start Guide
Guide de démarrage rapide

3 Wearing the headphone

1. Select the right ear tips

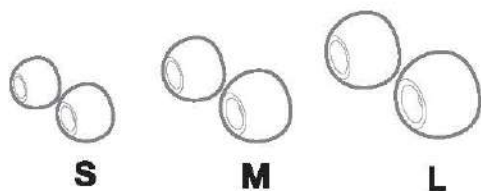

2. Wear behind the neck

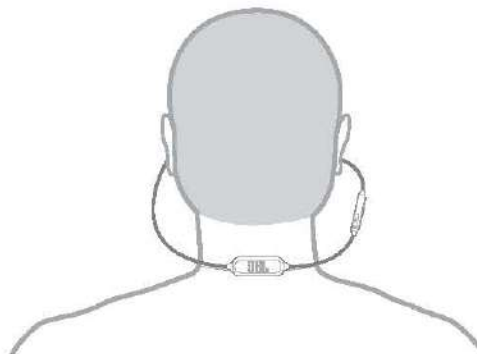

T110BT

Quick Start Guide
Guide de démarrage rapide

4 Bluetooth® connection

1. Turn on the headphone

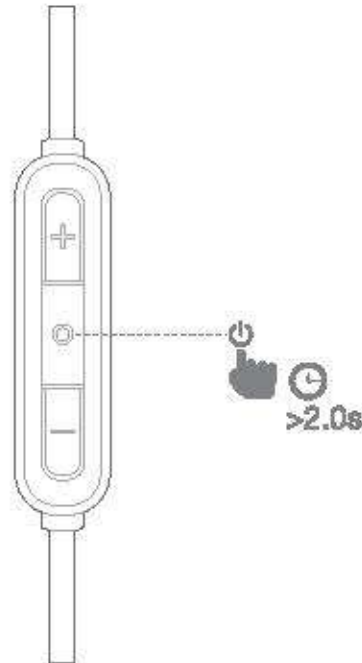

2. If connecting for the first time, the headphone will enter pairing mode automatically after it is powered on.

3. Connect to bluetooth device

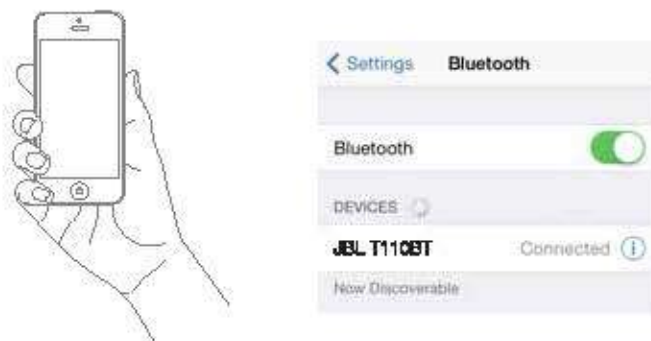

Choose "JBL T110BT" to connect

T110BT

Quick Start Guide
Guide de démarrage rapide

5 Music control

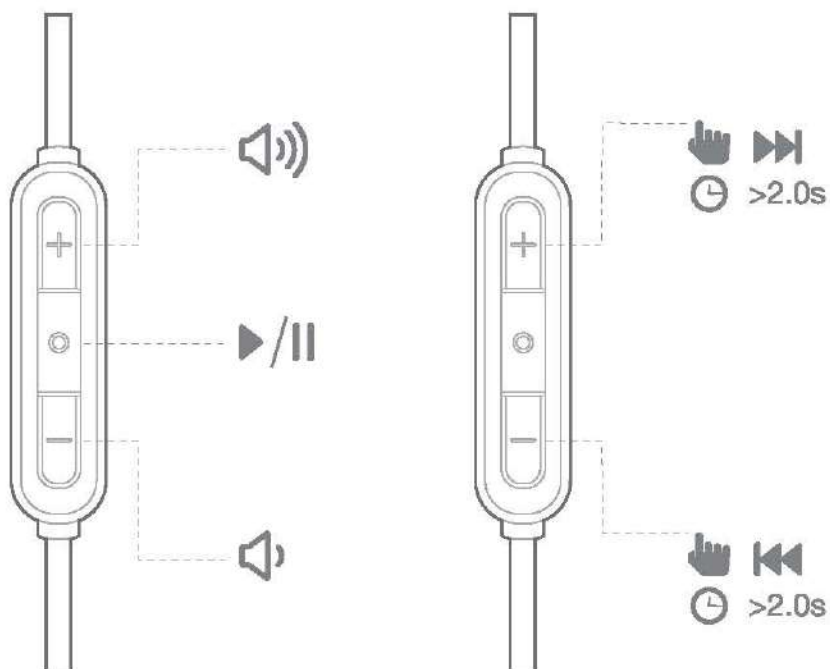

6 Phone call

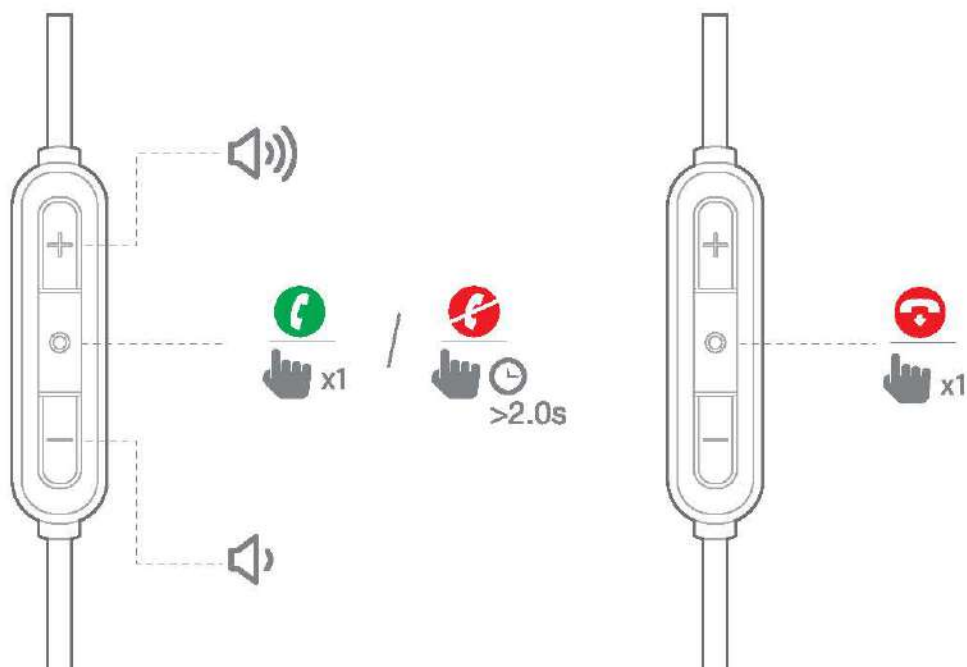

T110BT

Quick Start Guide
Guide de démarrage rapide

7 LED behaviour

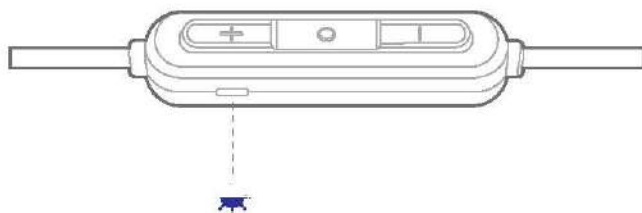

EN

Headphone mode	LED Status
① Power on	☀️ x1
① Power off	☀️ x1
No device connected	● On
🔗 BT Pairing	☀️ Fast
🔗 BT Connected	● On
🔋 Low battery	☀️ Slow
🔋 Charging in Progress	● On
🔋 Charging Complete	Off

T110BT

Quick Start Guide
Guide de démarrage rapide

Specifications

EN

- Driver size: 8mm
- Dynamic frequency response range: 20Hz-20kHz
- Sensitivity: 102dB
- Maximum SPL: 110dB
- Microphone Sensitivity:@1kHz Db v/pa: -42
- Impedance: 16ohm
- Bluetooth transmitter power: 0-4dbm
- Bluetooth transmitter modulation: GFSK, $\pi/4$ DQPSK, 8DPSK
- Bluetooth frequency: 2.402GHz-2.48GHz
- Bluetooth profiles: HFP v1.6, HSP v1.1, A2DP v1.2, AVRCP v1.5
- Bluetooth version: V4.1
- Battery type: (3.7V, 120mAh)
- Charging time: 2 hours
- Music play time with BT on: Up to 8 hours
- Talk time with BT on: Up to 8 hours
- Weight (kg): 16.5g

T110BT

Quick Start Guide

Guide de démarrage rapide

Торговая марка: JBL

Назначение товара: Пользовательские наушники

Изготовитель: Харман Интернешнл Индастриз Инкорпорейтед, США, 06901

Коннектикут, г.Стэмфорд, Атлантик Стрит 400, офис 1500

Страна происхождения: Китай

Импортер в Россию: ООО "ХАРМАН РУС СиАйЭс", РОССИЯ, 127018, г.МОСКВА, УЛ. ДВИНЦЕВ,

Д.12, КОРПУС 1

Гарантийный период: 1 год

Информация о сервисных центрах: www.harman.com/ru тел. +7-800-700-0467

Срок службы: 2 года

Срок хранения: не ограничен

Условия хранения: Стандартные при нормальных значениях климатических факторов

внешней среды

Номер документа соответствия: Товар не подлежит обязательной сертификации

Дата производства: Дата изготовления устройства определяется по двум буквенным обозначениям из второй группы символов серийного номера изделия, следующих после разделительного знака «-». Кодировка соответствует порядку букв латинского алфавита, начиная с января 2010 года:

000000-MY0000000, где «M» - месяц производства (A - январь,

B - февраль, C - март и т.д.) и «Y» - год производства

(A - 2010, B - 2011, C - 2012 и т.д.).

A	2010	N	2023
B	2011	O	2024
C	2012	P	2025
D	2013	Q	2026
E	2014	R	2027
F	2015	S	2028
G	2016	T	2029
H	2017	U	2030
I	2018	V	2031
J	2019	X	2032
K	2020	Y	2033
L	2021	Z	2034
M	2022	повторно начать с A	

T110BT

Quick Start Guide
Guide de démarrage rapide



Este equipamento opera em caráter secundário, isto é, não tem direito a proteção contra interferência prejudicial, mesmo de estações do mesmo tipo, e não pode causar interferência a sistemas operando em caráter primário"

Este produto está homologado pela ANATEL, de acordo com os procedimentos regulamentados pela Resolução 242/2000, e atende aos requisitos técnicos aplicados.

Para maiores informações, consulte o site da ANATEL - www.anatel.gov.br



XXXX-XX-XXXX



당해 무선설비는 전파혼신 가능성이 있으므로 인명안전과 관련된 서비스는 할 수 없음



The Bluetooth® word mark and logos are registered trademarks owned by Bluetooth SIG, Inc. and any use of such marks by HARMAN International Industries, Incorporated is under license. Other trademarks and trade names are those of their respective owners.